

M51348FP/AFP

POCKET TV IF SYSTEM

DESCRIPTION

The M51348 is a low supply voltage, low power semiconductor IC for compact TV sets which includes Video Intermediate Frequency (VIF), Sound Intermediate Frequency (SIF), and Synchronous Separation (Sync. Sep.) functions. An IF amplifier, video detector (with simultaneous sound detector), IF AGC, RF AGC (forward type), AFT, SIF limiter amplifier, FM detector, electronic volume, and synchronous separation function are provided. The package is of the 24-pin mini-flat type. The M51348AFP has better DG and DP but less VIF input sensitivity than the M51348FP.

FEATURES

- This IC can be used with very low supply voltage and low power and it comes in a mini-flat package to suit the compact TV or compact TV tuner.
Minimum operating power voltage3V
Consuming current16mA(when used with 4.5V supply voltage)
- Current automatically decreases to ensure power saving when a strong signal is received, when the AFT is not in use, i.e., when mute switch is ON, and when the electronic volume control is at its lowest.
- There are separate GND pins for the VIF/Sync. Sep. circuit and for the SIF circuit so that cross-interference is reduced.
- It is possible to adjust the video detector output amplitude by controlling the 24-pin voltage externally.

PIN CONFIGURATION (TOP VIEW)

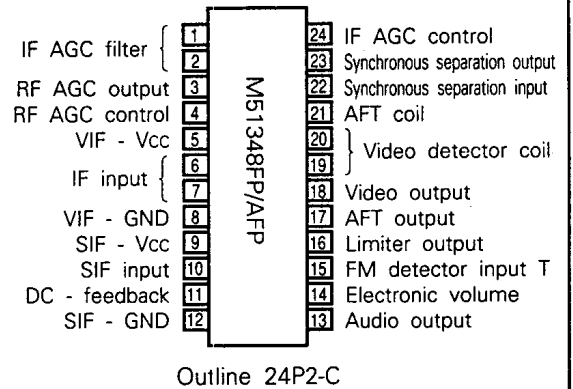

- The AGC works fast because of the 2-stage AGC filter. AGC has high stability against outside noise due to the AGC noise canceller.
- Emitter input circuit is used in Sync. Sep. Output is taken from the Sync. positive polarity.

APPLICATION

Portable B/W, color TV

RECOMMENDED OPERATING CONDITIONS

Supply voltage range3.0~6.0V
Rated supply voltage4.5V

BLOCK DIAGRAM

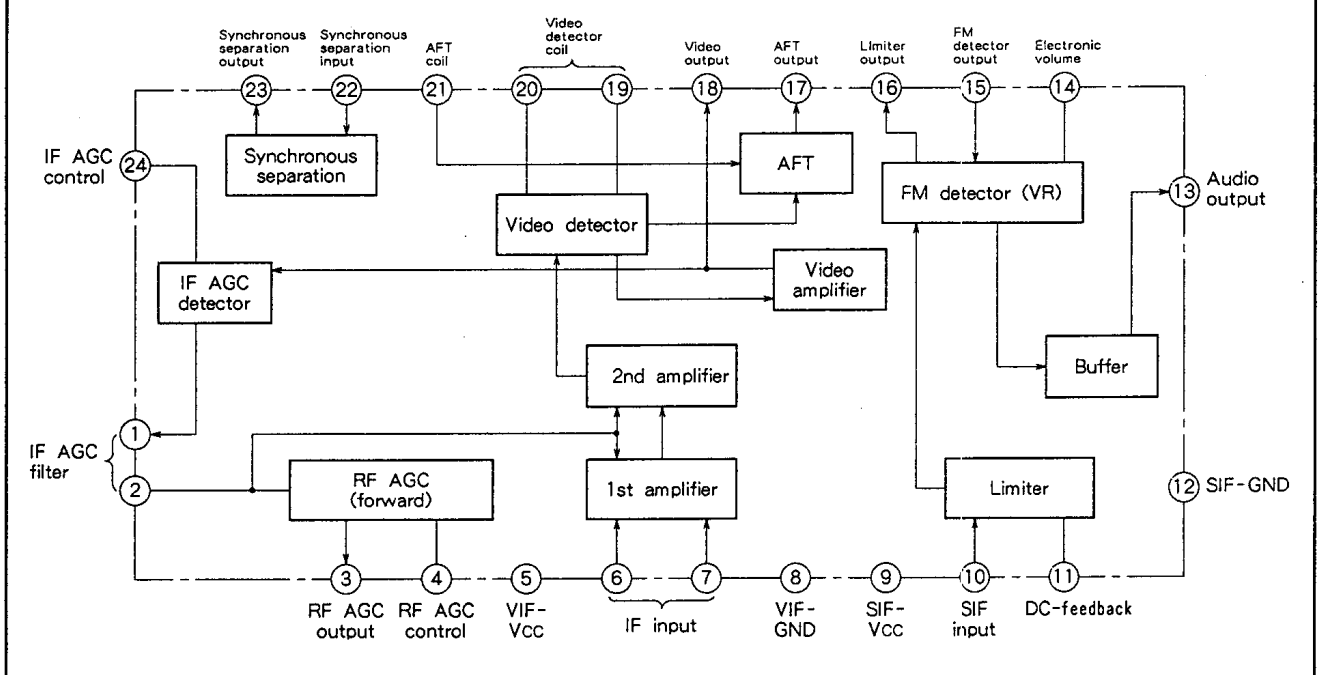

M51348FP/AFP

POCKET TV IF SYSTEM

ABSOLUTE MAXIMUM RATINGS

Symbol	Parameter	Ratings	Unit
V _{cc} (5)	Supply Voltage (1)	7.5	V
V _{cc} (9)	Supply Voltage (2)	7.5	V
P _d	Power Dissipation	500	mW
T _{opr}	Operating Temperature	- 20~75	°C
T _{stg}	Storage Temperature	- 40~125	°C

ELECTRICAL CHARACTERISTICS (T_a = 25°C, unless otherwise noted)

VIF SECTION

Symbol	Parameter	Test point	Input	Test conditions	Limits			Unit
					Min.	Typ.	Max.	
I _{vif}	Circuit current	⑤	SG1 90dB μ	Input current with 4.5V in ⑤	9	13.5	18	mA
V _{o det}	Video detector output	⑱	SG1 90dB μ	Output amplitude	0.7	0.9	1.1	V _{P-P}
V _{in min}	Input sensitivity	⑱	SG1 Variable	Input level when output amplitude reaches 3 dB less than V _{o det} .		45 (48)	50 (55)	dB μ
V _{in max}	Maximum allowable input	⑱	SG1 Variable	Input level when output amplitude reaches 3 dB more than V _{o det} .	90 (95)	109 (114)		dB μ
BW	Video frequency characteristic	⑱	SG2	BW is defined as f ₁ -f ₂ when output amplitude reaches -3 dB less than that when f ₁ -f ₂ = 1MHz.	6	7		MHz
V _{3H}	RF AGC maximum voltage	③	SG4 90dB μ	Output DC voltage with 4.5V in ④	3.2	3.7		V _{O-P}
V _{3L}	RF AGC minimum voltage	③	SG4 90dB μ	Output DC voltage with 2V in ④		0	0.2	V _{O-P}
μ	AFT detector sensitivity	⑰	SG5 90dB μ		30	42		mV/kHz
V _{M17}	DC voltage at AFT mute ON	⑰	SG5 90dB μ	Output DC voltage with 0V in ⑳	2	2.25	2.5	V
V _{AC}	AFT center voltage	⑰		Output DC voltage with 0V in ⑳	0.5	1.4	2.5	V
V _{sync}	Sync. Sep. output voltage	㉓	SG1 90dB μ	Output amplitude	3.5	3.8	4.1	V _{P-P}
V _{OH det}	Video detector output at high or low voltage	⑱	SG1 90dB μ	Output amplitude with 6.0V or 3.0V in ⑤	0.95	1.25	1.55	V _{P-P}
V _{OL det}					0.35	0.6	0.85	

Note: () indicates value for the M51348AFP.

M51348FP/AFP

POCKET TV IF SYSTEM

ELECTRICAL CHARACTERISTICS SIF SECTION

Symbol	Parameter	Test point	Input	Test conditions	Limits			Unit
					Min.	Typ.	Max.	
I _{sif}	Circuit current	⑨		Input current with 4.5V in ⑨	2.0	2.8	3.6	mA
V _{o AF}	Detector output voltage	⑬	SG6 90dB μ	Output amplitude	220	270	320	mVrms
V _{i min}	Input limiting sensitivity	⑬	SG6 Variable	Input level when input amplitude reaches -3dB below V _{o AF} .		35	49	dB μ
AMR	AM rejection ratio	⑬	SG7 90dB μ	AMR = 20 log, where V _{AM} denotes output amplitude. AMR = 20 log $\left(\frac{V_{o AF} (mVrms)}{V_{AM} (mVrms)}\right)$	40	60		dB
BW (s)	Bandwidth	⑬	SG8 90dB μ		100	130		kHz
VR1	Electronic volume control characteristic	⑬	SG6 90dB μ	Ratio of output amplitude and V _{o AF} when ⑩ is changed from 4.0V to 1.0V.	3.3	3.75	4.2	dB
VR2						-63	-52	dB
THD	Distortion	⑬	SG9 90dB μ	Measured by distortion meter		0.8	1.2	%
V _{OHAF}	Detector output voltage at high or low voltage	⑬	SG6 90dB μ	Output amplitude with 6.0V or 3.0V in ⑨	380	430	480	mVrms
V _{OLAF}					53	64	75	mVrms

Note: ○ indicates measuring circuit.

PRECAUTIONS CONCERNING ELECTRICAL CHARACTERISTICS

- Voltage supplied (pins ⑤ and ⑨) is 4.5V unless otherwise noted in the conditions column.
- VIF input amplitude (V_{in}) is the amplitude of VIF IN in the circuit below. Feed SG1 90dB μ signal into the circuit below, and measure the DC voltage V₂ at ②. Set the circuit for AC voltage measurement and adjust the input amplitude, monitoring DC voltage at ②, until it reaches the level of V₂. 90dB μ is defined as the input amplitude at that time.

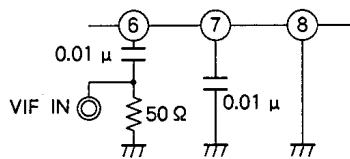

- Input signals are shown below.

- SG1 f₀=58.75MHz f_m=20kHz 77.8%AM
- SG2 f₁=58.75MHz V_i=90dB μ CW } mixed signal
- f₂=53 \pm 5MHz V_i=70dB μ CW }
- SG3 f₀=58.75MHz LINEARITY 10step signal
(87.5%Video modulation)
- SG4 f₀=58.75MHz CW
- SG5 f₀=58.75 \pm 5MHz CW (Sweep)
- SG6 f₀=4.5MHz FM25kHz dev f_m=400Hz

SG7 f₀=4.5MHz AM30% f_m=400Hz

SG8 f₀=4.5MHz \pm 200kHz FM7.5kHz dev
f_m=400Hz

SG9 f₀=4.5MHz FM7.5kHz dev f_m=400Hz

- Adjustment of LLD coil

- 1) Feed SG5 V_i=90dB μ into VIF IN.
- 2) AFT coil must be shifted to detuned condition.
- 3) Feed outside voltage to ② and check tank response at ⑱ as shown in the figure below.
- 4) Adjust LLD coil so that peak comes at 58.75MHz.

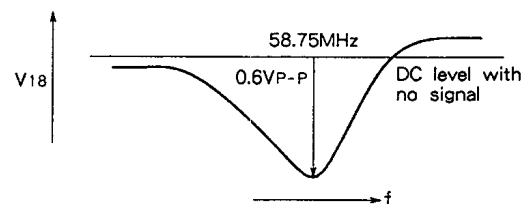

M51348FP/AFP

POCKET TV IF SYSTEM

5. Adjustment of AFT coil

- 1) Feed SG5 $V_i=90\text{dB}\mu$ in VIF IN.
- 2) Measure the voltage at pin ⑰ and adjust AFT coil as shown in the figure below.

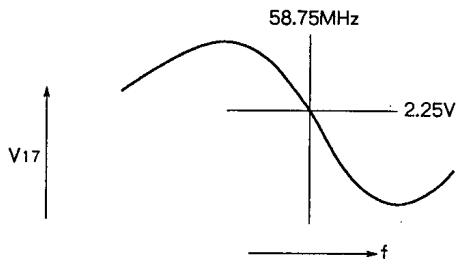

μ : AFT detector sensitivity " μ "

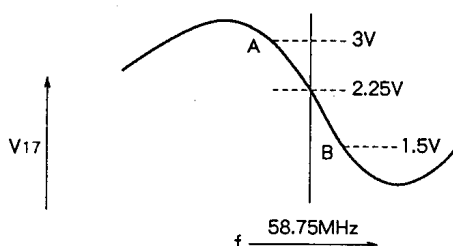

$$\mu = \frac{1500\text{mV}}{f_B(\text{kHz}) - f_A(\text{kHz})}$$

where f_A denotes a frequency at A and f_B at B.

BW(s): Bandwidth "BW(s)"

First, define $V_{0(\text{DET})\text{ FM}}$ as the output amplitude when the signal $f_0=4.5\text{MHz}$, $f_m=400\text{Hz}$ and $f_{\text{dev}}=\pm 7.5\text{kHz}$ is given to SIF IN.

Second, decrease and increase the frequency f_0 until the output amplitude reaches -3dB than $V_{0(\text{DET})\text{ FM}}$. These are defined as f_{0L} and f_{0H} , respectively. Bandwidth is defined as $\text{BW}(s)=f_{0H}-f_{0L}$.

TEST CIRCUIT

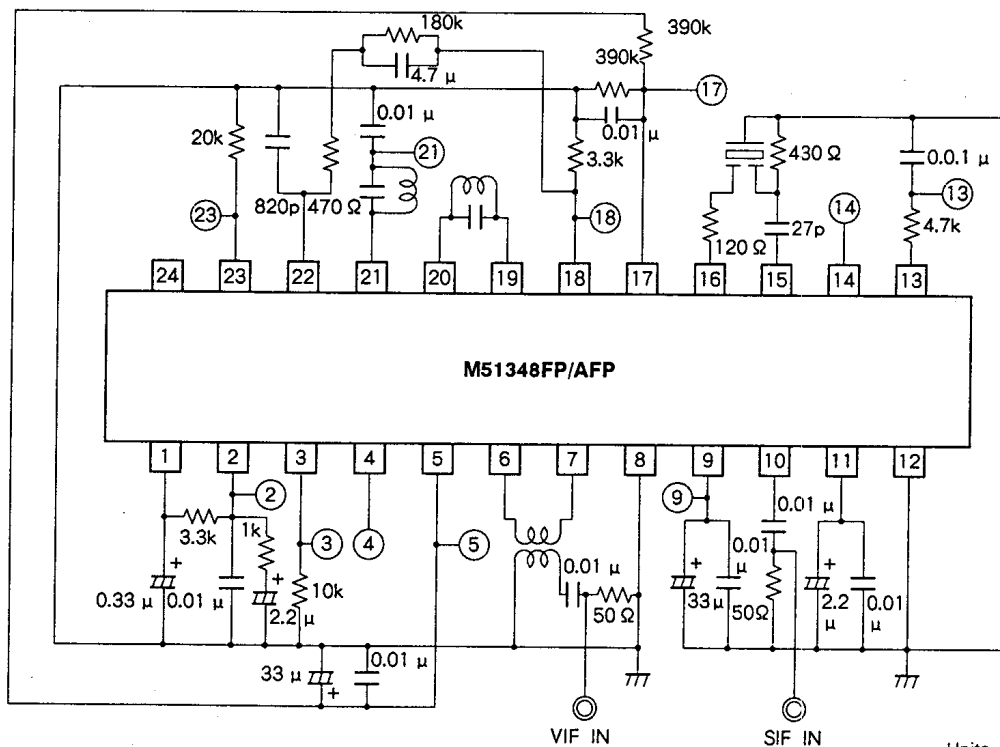

Units Resistance: Ω
Capacitance: F

M51348FP/AFP

POCKET TV IF SYSTEM

TYPICAL CHARACTERISTICS

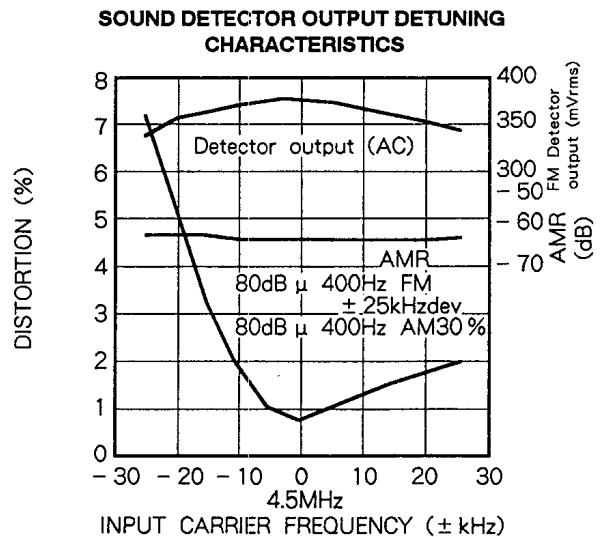
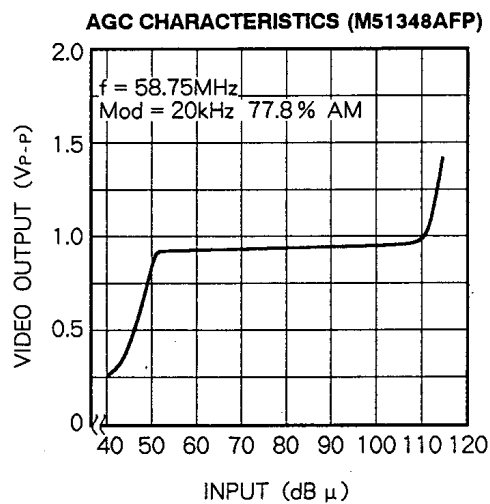
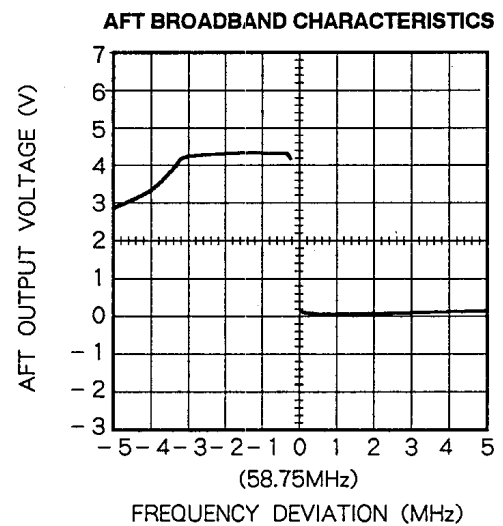
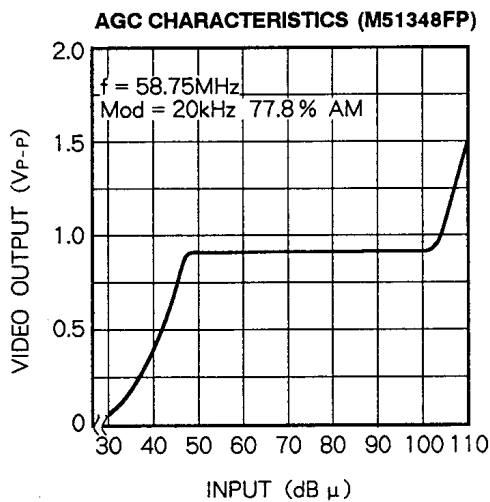
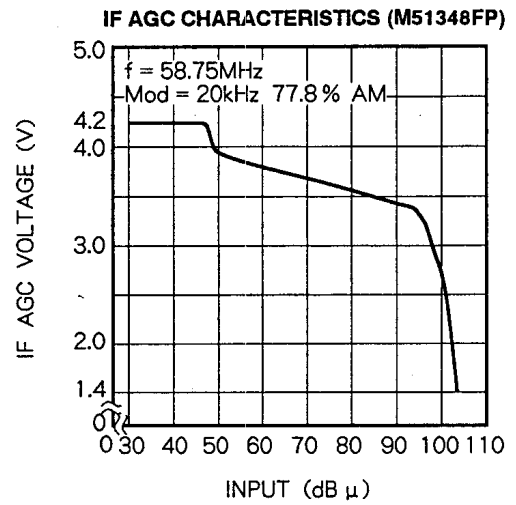
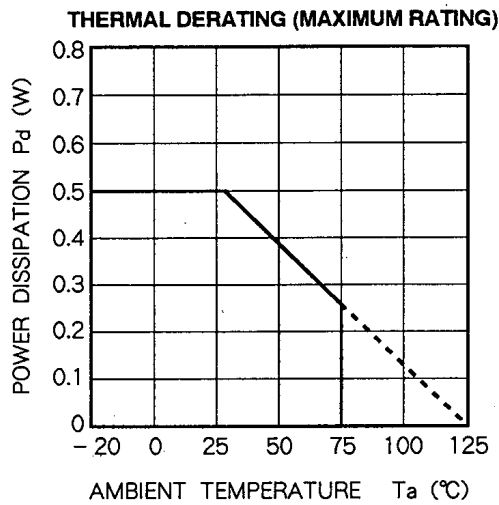

IF AGC CHARACTERISTICS (M51348AFP)

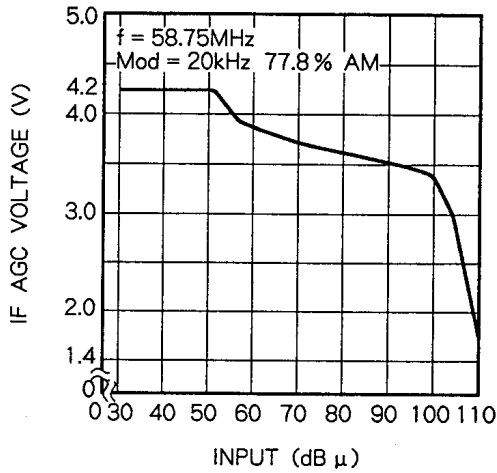

SIF LIMITING CHARACTERISTICS AND AMR CHARACTERISTICS

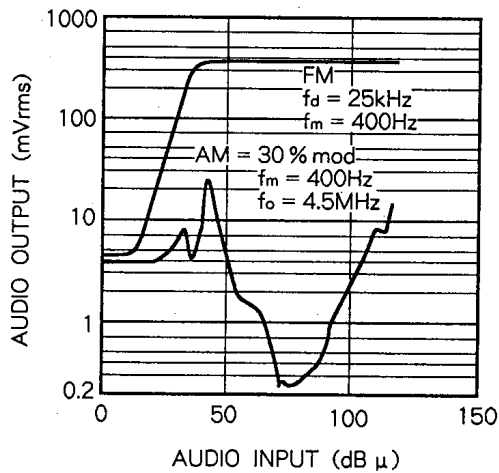

SOUND OUTPUT ELECTRONIC VOLUME CONTROL CHARACTERISTICS

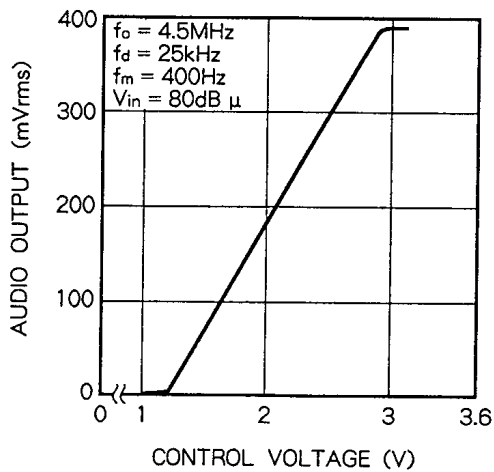

M51348FP/AFP

POCKET TV IF SYSTEM

APPLICATION EXAMPLE

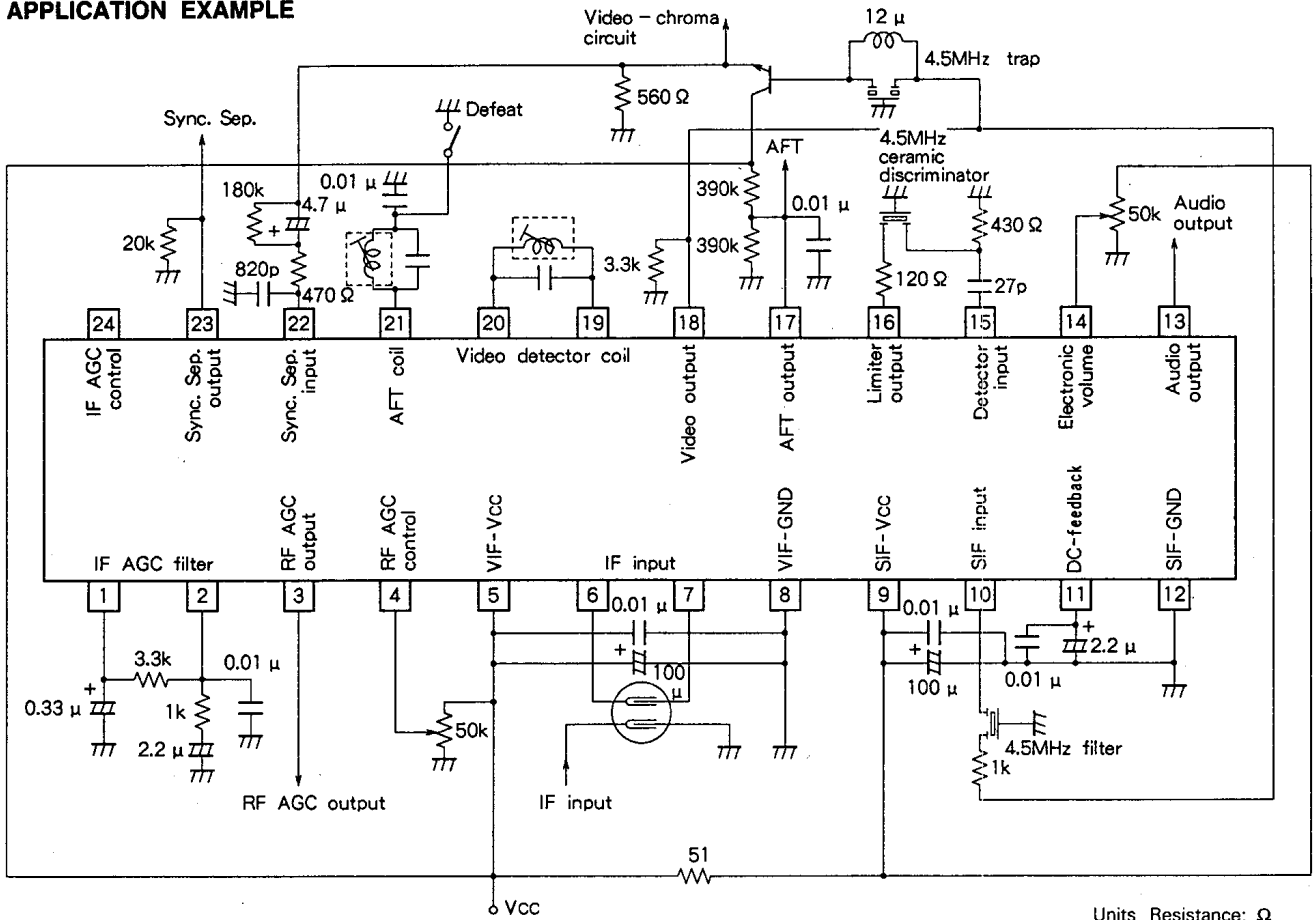

Units Resistance: Ω
Capacitance: F

M51348FP/AFP

POCKET TV IF SYSTEM

DESCRIPTION OF PIN

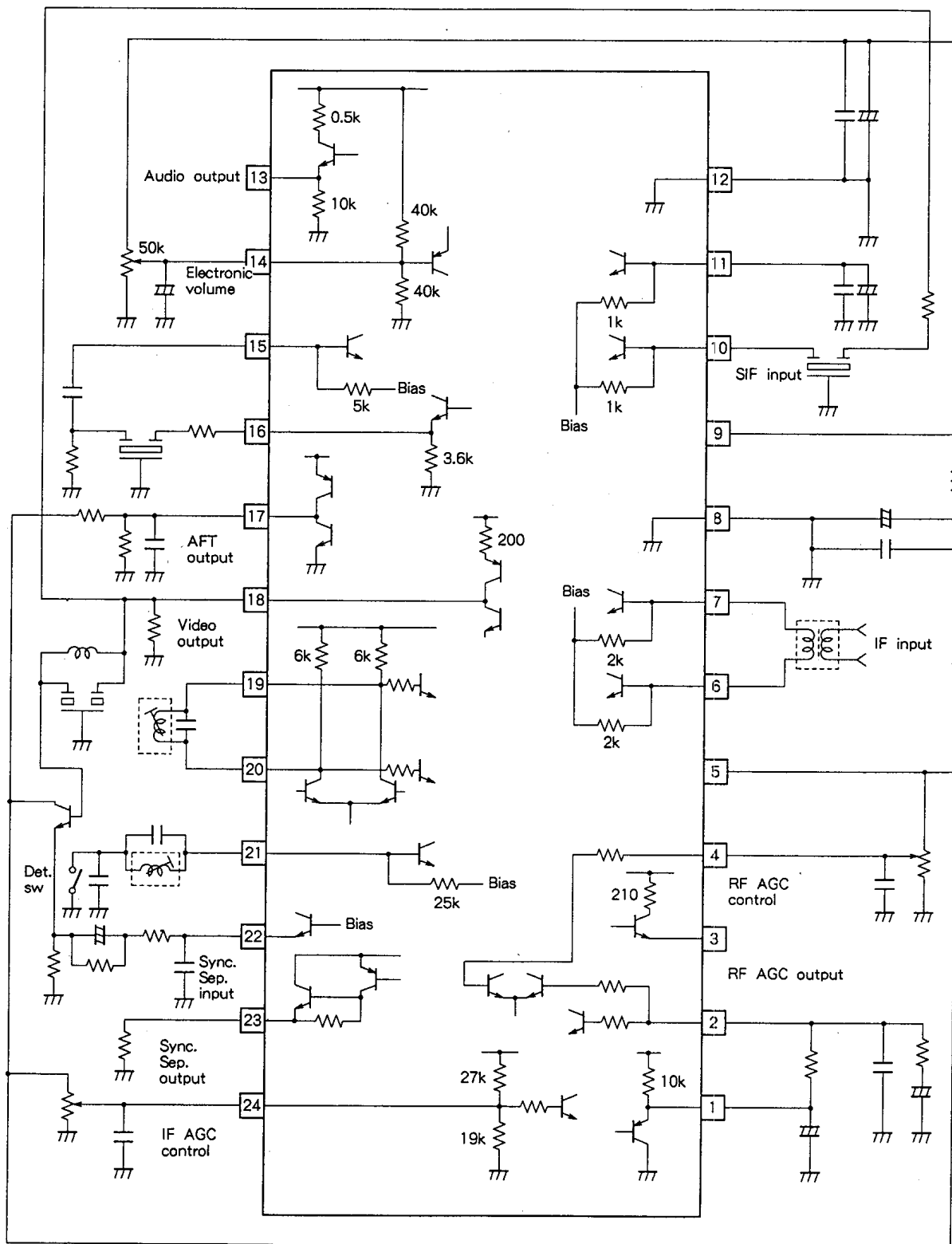

Units Resistance: Ω
Capacitance: F

PRECAUTIONS FOR APPLICATION

1. Operating supply voltage

This IC can be used with 3~6V. Within this range, the higher the supply voltage is, the greater the current dissipation is and the higher the performance is. However, VIF input sensitivity reaches a high level with high Vcc, so care must be taken with amplifier oscillation. Separate power supplies may be used for VIF and SIF..

2. AFT operation

The AFT coil pin should be grounded (Pin 21) if AFT circuit is not in use. This reduces current dissipation of the AFT block.

3. IF AGC control (Pin 24)

This pin has 0.9V_{P-P} voltage with no connection. The lower the outside voltage to Pin 24 is, the higher the detector output becomes.

4. FM detector circuit (Pin 15, 16)

The following circuit is recommended if a coil is used.

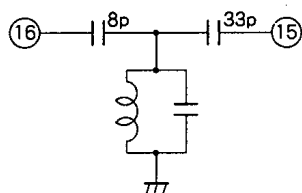

5. Electronic volume control (Pin 14)

This pin has Vcc/2 voltage inside. Detector output and circuit current change from max. to min. corresponding to outside voltage change from Vcc to 0V. Input Vcc or leave Pin 14 open when electronic volume control is not in use.

6. DG/DP

The M51348FP and AFP, and 10k coil and 5k coil types have standard differences as follows:

	10k coil (Q ≈ 72)	5k coil (Q ≈ 75)
M51348FP	15%/5deg	20%/7deg
M51348AFP	10%/4deg	7%/3deg

LLD, AFT Coil Example
 5k 4turn 47pF Q=75