

AM SIF CIRCUIT

- SOUND AM SYNCHRONOUS DEMODULATOR
- AM/FM AUDIO SWITCH
- AV/TV AUDIO SWITCH
- MUTE INPUT

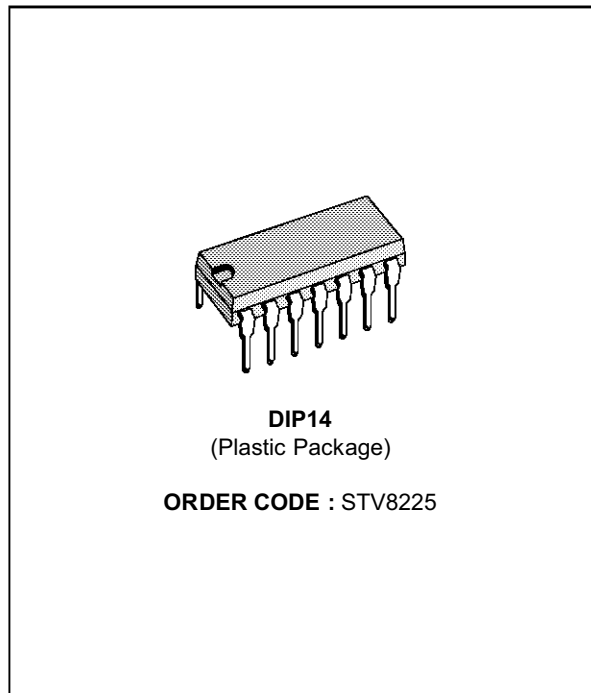

DESCRIPTION

The STV8225 is intended for the demodulation of the AM sound of the L standard.

Used as an add on to the STV8224 it permits to design a multistandard set with the needed switches for one SCART plug.

PIN CONNECTIONS

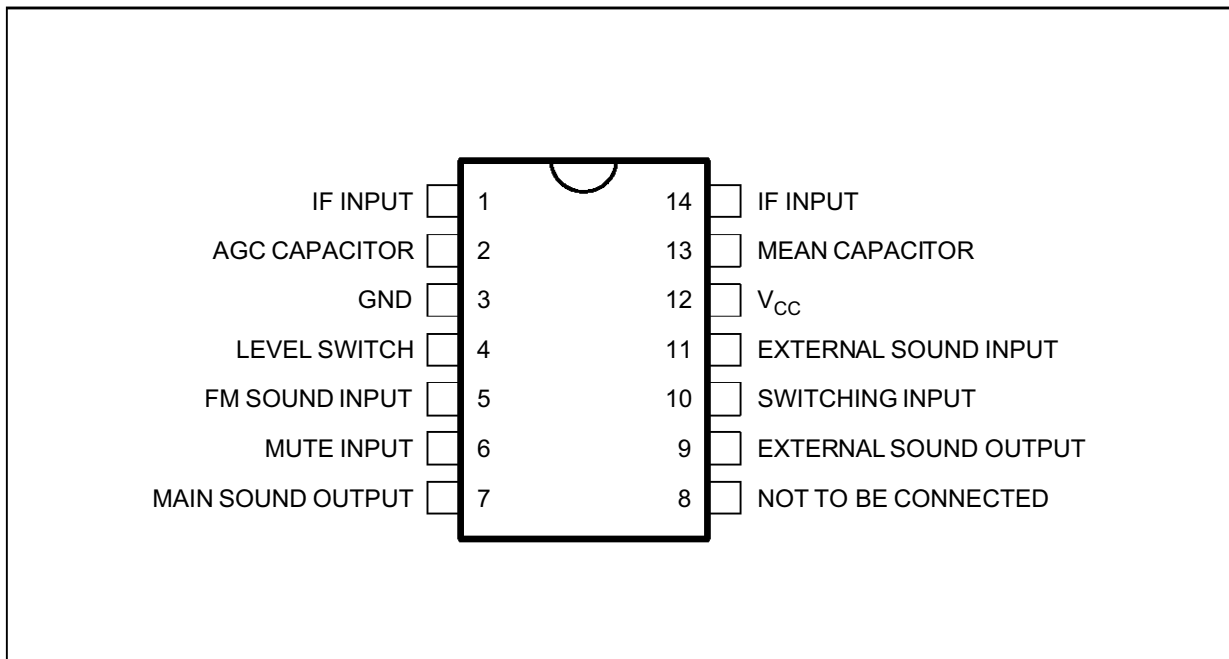

8225-01.EPS

BLOCK DIAGRAM

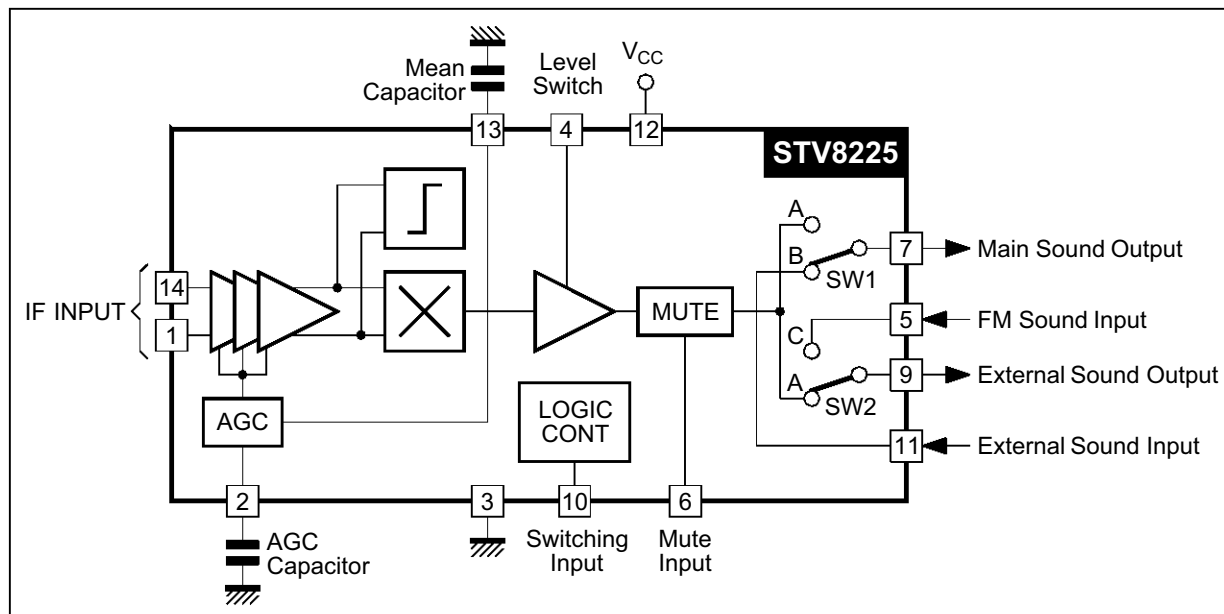

ABSOLUTE MAXIMUM RATINGS

Symbol	Parameter	Value	Unit
V _{CC}	Supply Voltage	13	V
T _{stg}	Storage Temperature	-40, +150	°C
T _{oper}	Operating Temperature	0, +70	°C
P _{tot}	Power Dissipation	0.35	W

THERMAL DATA

Symbol	Parameter	Value	Unit
R _{th(j-a)}	Junction-ambient Thermal Resistance	Max. 90	°C/W

ELECTRICAL CHARACTERISTICS (V_{CC} = 9V, V_{IN} = 10mV_{RMS}, f_{SC} = 32.4MHz, f_M = 1kHz, m = 54% modulation depth, Audio BW = 40Hz to 15kHz, T_{amb} = 25°C, unless otherwise specified)

Symbol	Parameter	Test Conditions	Min.	Typ.	Max.	Unit
V _{CC}	Supply Voltage	Pin 12	8	9	10	V
I _{CC}	Supply Current	Pin 12		20	30	mA
	Supply Voltage Rejection	Pins 9, 7, 12 - V _{Ripple} = 0.5V _{PP} , f = 100Hz	45	53		dB

IF AMPLIFIER

R _i 1, 14	Input Resistance (Pins 1-14)	Resistance between Pin 1 and 14		2		kΩ
C _i 1, 14	Input Capacitance (Pins 1-14)	Capacitance between Pin 1 and 14		2		pF
V _{IF min}	Minimum IF Input Signal	IF input signal for V _{OUT} = V _{NOM} - 3dB		70		μV _{RMS}
V _{IF max}	Maximum IF Input Signal	IF input signal for V _{OUT} = V _{NOM} + 1dB		75		mV _{RMS}
DAV	AGC Range	DAV = V _{IF max} / V _{IF min}		61		dB
I _{AGC}	Maximum AGC Output Current (Pin 2)	Charging and discharging	±35	±50	±65	μA
	IF Bandwidth	-3dB		50		MHz

ELECTRICAL CHARACTERISTICS (continued) ($V_{CC} = 9V$, $V_{IN} = 10mV_{RMS}$, $f_{SC} = 32.4MHz$, $f_M = 1kHz$, $m = 54\%$ modulation depth, Audio BW = 40Hz to 15kHz, $T_{amb} = 25^{\circ}C$, unless otherwise specified)

Symbol	Parameter	Test Conditions	Min.	Typ.	Max.	Unit
AM DEMODULATOR						
	AF Output Voltage (Pins 7-9)	Level switch (Pin 4) open Level switch (Pin 4) connected to GND	200 400	250 500	300 600	mV_{RMS} mV_{RMS}
	AF Bandwidth (Pins 7-9) Lower Limit Upper Limit	-3dB versus nominal signal	50		40	Hz kHz
	Harmonic Distorsion (Pins 7-9)	THD + Noise		0.7	1.8	%
	S/N (Pins 7-9)	Weighted according to CCIR 468-4		55		dB

MUTE

	Threshold Level (Pin 6)	Mute mode if voltage below threshold	0.2	0.3	0.4	V
	Attenuation (Pins 7-9)	Level switch (Pin 4) connected to GND TV - AM mode	80	96		dB

AUDIO SWITCHES

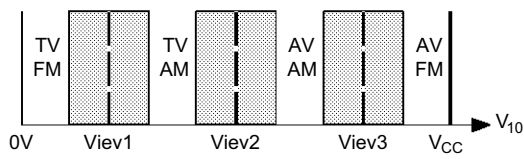
	Switching Voltage (Pin 10)	Operation mode 				
View1	Level 1 (Pin 10)	For voltage below this level TV-FM mode : Pin 7 connected to A Pin 9 connected to C	1.8	2.3	2.6	V
View2	Level 2 (Pin 10)	For voltage below this level TV-AM mode : Pin 7 connected to A Pin 9 connected to A	4.1	4.6	4.9	V
View3	Level 3 (Pin 10)	For voltage below this level AV-AM mode : Pin 7 connected to B Pin 9 connected to A For voltage above this level AV-FM mode : Pin 7 connected to B Pin 9 connected to C	6.4	6.8	7.2	V
	Input Current (Pin 10)	Source current		0.3	2	μA
	Input Dynamic Range (Pins 5-11)		2			V_{RMS}
	Input Resistance (Pins 5-11)		35	50		k Ω
	Switch Gain	$V_{IN} = 2V_{RMS}$, $f = 1kHz$ Pin 7 vs Pin 11 and Pin 9 vs Pin 5	-0.6	-0.1	0.4	dB
	Crosstalk	$f = 1kHz$	70	85		dB
	Output Resistance (Pins 7-9)		70	100	130	Ω
	Output Current Source (Pins 7-9)			1		mA
	Switch Distorsion	$V_{IN} = 2V_{RMS}$, $f = 1kHz$, THD + Noise, Pin 7 vs Pin 11 and Pin 9 vs Pin 5		0.1	0.5	%
	Output Noise	Unweighted		7	20	μVp
	DC Plop at AF Output Pin			10	50	mV

8225-04.TBL

APPLICATION DIAGRAM
STV8224 - STV8225

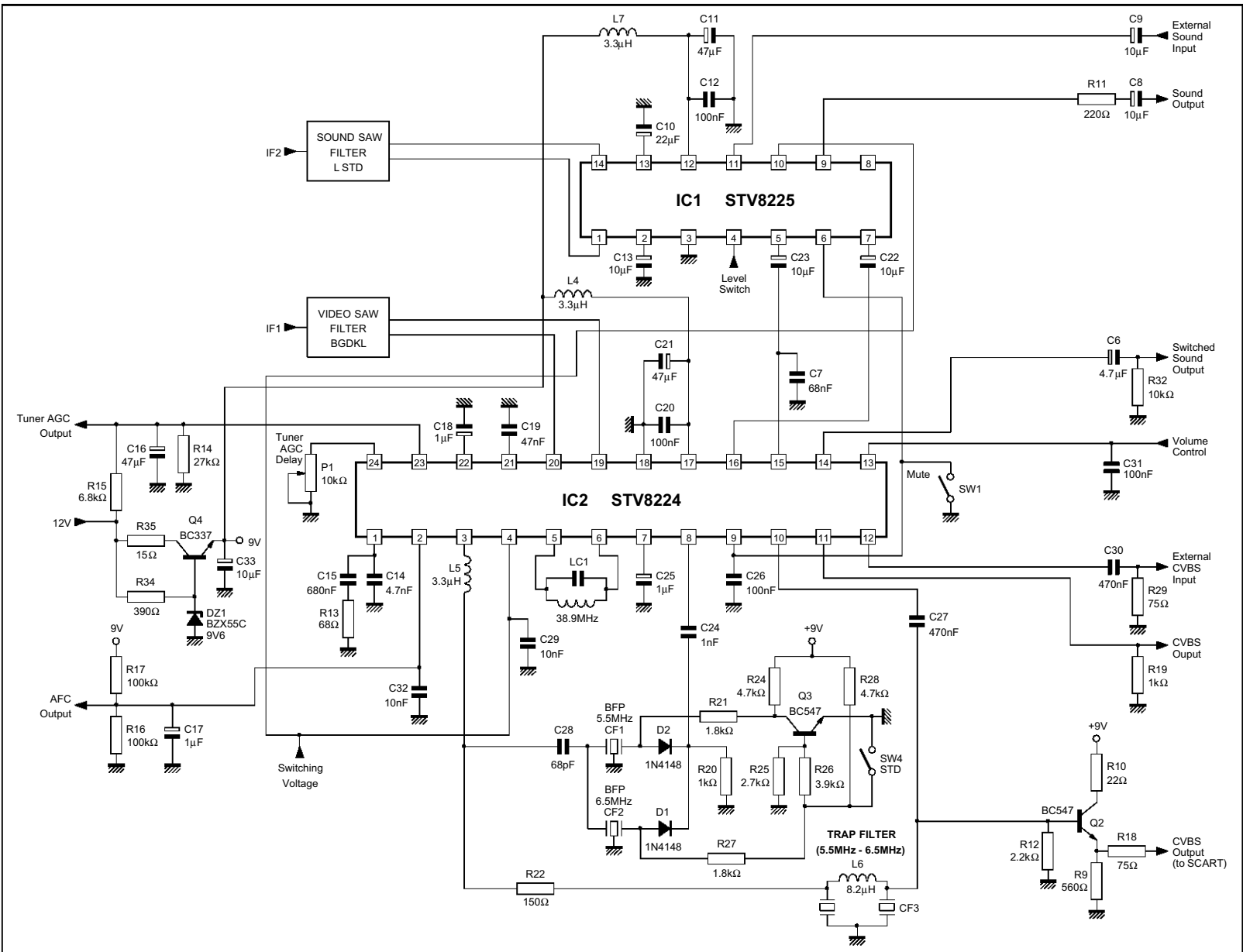

INPUT/OUTPUT PINS CONFIGURATION

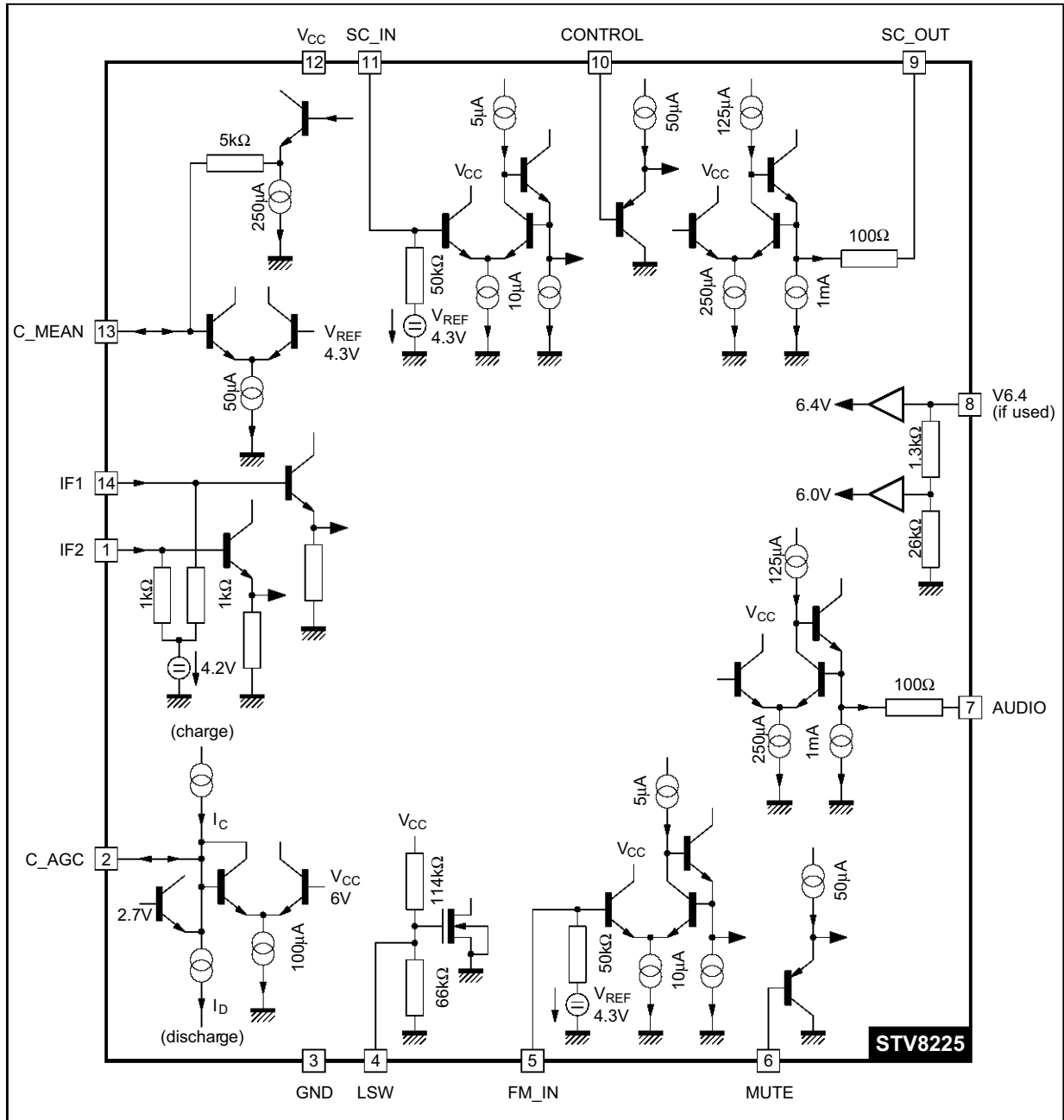

8225-04.EPS

PACKAGE MECHANICAL DATA
14 PINS - PLASTIC DIP

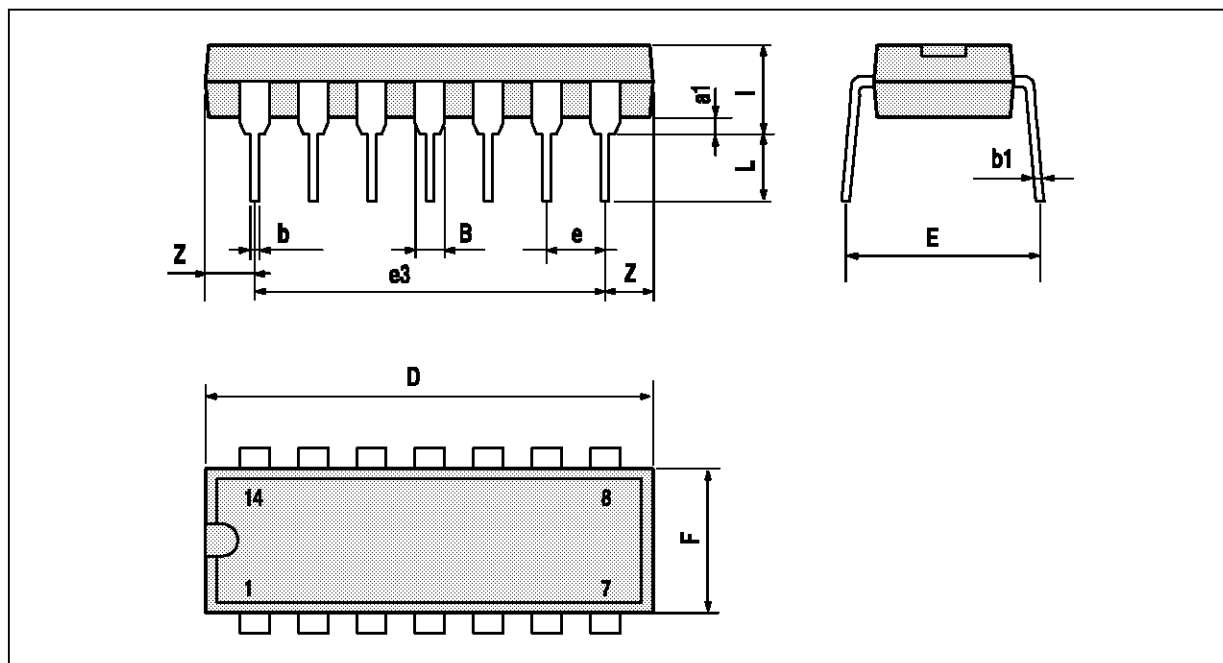

PM-DIP14.WMF

Dimensions	Millimeters			Inches		
	Min.	Typ.	Max.	Min.	Typ.	Max.
a1	0.51			0.020		
B	1.39		1.65	0.055		0.065
b		0.5			0.020	
b1		0.25			0.010	
D			20			0.787
E		8.5			0.335	
e		2.54			0.100	
e3		15.24			0.600	
F			7.1			0.280
i			5.1			0.201
L		3.3			0.130	
Z	1.27		2.54	0.050		0.100

DIP14.TBL

Information furnished is believed to be accurate and reliable. However, SGS-THOMSON Microelectronics assumes no responsibility for the consequences of use of such information nor for any infringement of patents or other rights of third parties which may result from its use. No licence is granted by implication or otherwise under any patent or patent rights of SGS-THOMSON Microelectronics. Specifications mentioned in this publication are subject to change without notice. This publication supersedes and replaces all information previously supplied. SGS-THOMSON Microelectronics products are not authorized for use as critical components in life support devices or systems without express written approval of SGS-THOMSON Microelectronics.

© 1995 SGS-THOMSON Microelectronics - All Rights Reserved

Purchase of I²C Components of SGS-THOMSON Microelectronics, conveys a license under the Philips I²C Patent. Rights to use these components in a I²C system, is granted provided that the system conforms to the I²C Standard Specifications as defined by Philips.

SGS-THOMSON Microelectronics GROUP OF COMPANIES

Australia - Brazil - China - France - Germany - Hong Kong - Italy - Japan - Korea - Malaysia - Malta - Morocco
The Netherlands - Singapore - Spain - Sweden - Switzerland - Taiwan - Thailand - United Kingdom - U.S.A.