

Silicon NPN Power Transistors

2SD2061

DESCRIPTION

- With TO-220Fa package
- Low collector saturation voltage
- Excellent DC current gain characteristics
- Wide safe operating area

APPLICATIONS

- For low frequency power amplifier applications

PINNING

PIN	DESCRIPTION
1	Base
2	Collector
3	Emitter

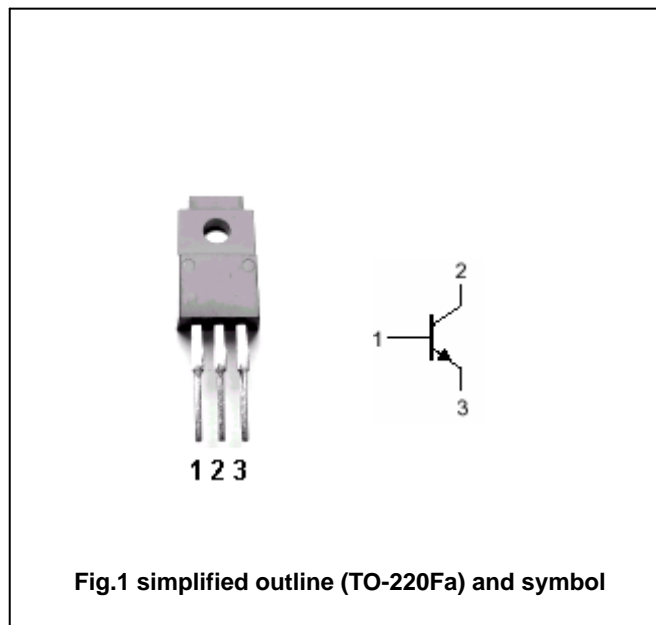

Absolute maximum ratings (Ta=25)

SYMBOL	PARAMETER	CONDITIONS	VALUE	UNIT
V _{CBO}	Collector-base voltage	Open emitter	80	V
V _{CEO}	Collector-emitter voltage	Open base	60	V
V _{EBO}	Emitter-base voltage	Open collector	5	V
I _C	Collector current (DC)		3	A
I _{CM}	Collector current-Peak		6	A
P _C	Collector power dissipation	T _C =25	30	W
		T _a =25	2	
T _j	Junction temperature		150	
T _{stg}	Storage temperature		-55~150	

Silicon NPN Power Transistors

2SD2061

CHARACTERISTICS

T_j=25 unless otherwise specified

SYMBOL	PARAMETER	CONDITIONS	MIN	TYP.	MAX	UNIT
V _{(BR)CEO}	Collector-emitter breakdown voltage	I _C =1mA, I _B =0	60			V
V _{(BR)CBO}	Collector-base breakdown voltage	I _C =50 μA, I _E =0	80			V
V _{(BR)EBO}	Emitter-base breakdown voltage	I _E =50 μA, I _C =0	5			V
V _{CEsat}	Collector-emitter saturation voltage	I _C =2A; I _B =0.2A			1.0	V
V _{BEsat}	Base-emitter saturation voltage	I _C =2A; I _B =0.2A			1.5	V
I _{CBO}	Collector cut-off current	V _{CB} =60V, I _E =0			10	μA
I _{EBO}	Emitter cut-off current	V _{EB} =4V; I _C =0			10	μA
h _{FE}	DC current gain	I _C =0.5A; V _{CE} =5V	100		320	
f _T	Transition frequency	I _C =0.5A; V _{CE} =5V; f=5MHz		8		MHz
C _{ob}	Output capacitance	I _E =0; V _{CB} =10V, f=1MHz		70		pF

◆ h_{FE} Classifications

E	F
100-200	160-320

Silicon NPN Power Transistors

2SD2061

PACKAGE OUTLINE

