

Silicon NPN Power Transistors

2SD1545

DESCRIPTION

- With TO-3P(H)IS package
- High voltage ,high speed
- Low collector saturation voltage

APPLICATIONS

- Color TV horizontal output applications
- Switching regulator output applications

PINNING

PIN	DESCRIPTION
1	Base
2	Collector
3	Emitter

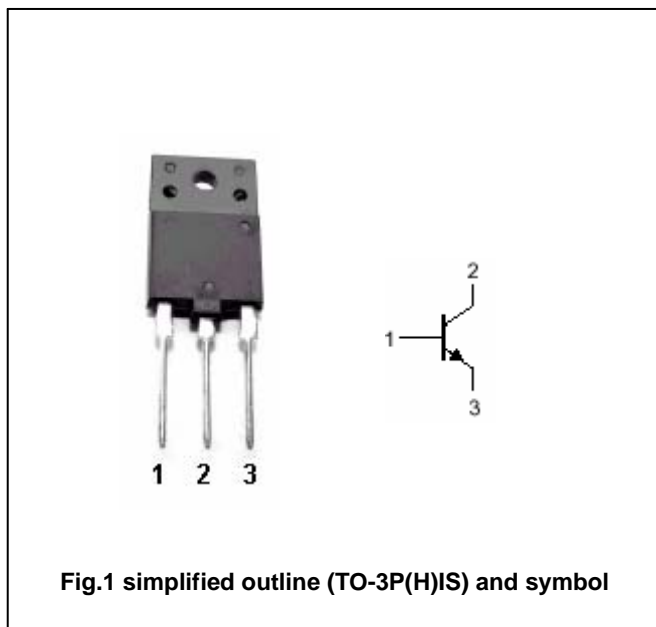

Absolute maximum ratings (Ta=25)

SYMBOL	PARAMETER	CONDITIONS	VALUE	UNIT
V _{CBO}	Collector-base voltage	Open emitter	1500	V
V _{CEO}	Collector-emitter voltage	Open base	600	V
V _{EBO}	Emitter-base voltage	Open collector	5	V
I _C	Collector current		5	A
I _B	Base current		2.5	A
P _C	Collector power dissipation	T _C =25	50	W
T _j	Junction temperature		150	
T _{stg}	Storage temperature		-55~150	

Silicon NPN Power Transistors

2SD1545

CHARACTERISTICS

T_j=25 unless otherwise specified

SYMBOL	PARAMETER	CONDITIONS	MIN	TYP.	MAX	UNIT
V _{CEsat}	Collector-emitter saturation voltage	I _C =4A ; I _B =0.8A		3.0	5.0	V
V _{BEsat}	Base-emitter saturation voltage	I _C =4A ; I _B =0.8A			1.5	V
I _{CBO}	Collector cut-off current	V _{CB} =500V; I _E =0			10	μA
I _{EBO}	Emitter cut-off current	V _{EB} =5V; I _C =0			1	mA
h _{FE}	DC current gain	I _C =1A ; V _{CE} =5V	8	20		
f _T	Transition frequency	I _C =0.1A ; V _{CE} =10V		3		MHz
C _{OB}	Collector output capacitance	I _E =0 ; V _{CB} =10V; f=1MHz		165		pF
t _f	Fall time	I _{CP} =4A ; I _{B1(end)} =0.8A		0.5	1.0	μs

Silicon NPN Power Transistors

2SD1545

PACKAGE OUTLINE

