

Silicon NPN Power Transistors

BU4508DF

DESCRIPTION

- With TO-3PFa package
- High voltage
- High speed switching
- Built-in damper diode

APPLICATIONS

- For use in horizontal deflection circuits of colour TV receivers.

PINNING

PIN	DESCRIPTION
1	Base
2	Collector
3	Emitter

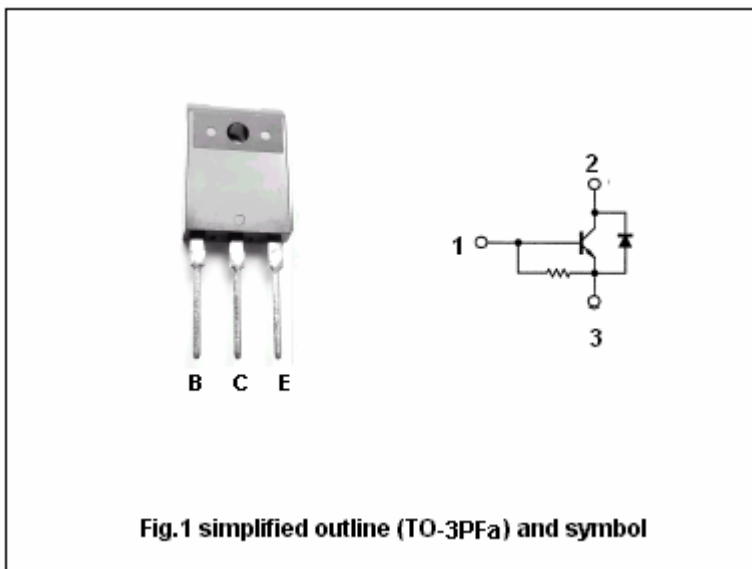

Fig.1 simplified outline (TO-3PFa) and symbol

Absolute maximum ratings(Ta=25)

SYMBOL	PARAMETER	CONDITIONS	VALUE	UNIT
V _{CBO}	Collector-base voltage	Open emitter	1500	V
V _{CEO}	Collector-emitter voltage	Open base	800	V
I _C	Collector current (DC)		8	A
I _{CM}	Collector current -peak		15	A
I _B	Base Collector current (DC)		4	A
I _{BM}	Base current-peak		6	A
P _{tot}	Total power dissipation	T _C =25	45	W
T _j	Max.operating junction temperature		150	
T _{stg}	Storage temperature		-65~150	

Silicon NPN Power Transistors

BU4508DF

CHARACTERISTICS

T_j=25 unless otherwise specified

SYMBOL	PARAMETER	CONDITIONS	MIN	TYP.	MAX	UNIT
V _{CEO(SUS)}	Collector-emitter sustaining voltage	I _C =100mA ; I _B =0, L=25mH	800			V
V _{(BR)EBO}	Emitter-base breakdown voltage	I _E =600mA ; I _C =0	7.5	13.5		V
V _{CEsat}	Collector-emitter saturation voltage	I _C =5A ; I _B =1.25A			3	V
V _{BEsat}	Base-emitter saturation voltage	I _C =5A ; I _B =1.25A			1.03	V
I _{CES}	Collector cut-off current	V _{CE} =BV _{CES} ; V _{BE} =0 T _C =125			1.0 2.0	mA
h _{FE-1}	DC current gain	I _C =0.5A ; V _{CE} =5V		7		
h _{FE-2}	DC current gain	I _C =5A ; V _{CE} =5V	4.2		7.3	
V _F	Diode forward voltage	I _F =5A			2.2	V

Silicon NPN Power Transistors

BU4508DF

PACKAGE OUTLINE

