

Silicon NPN Power Transistor

BU2708AF

DESCRIPTION

- Collector-Emitter Sustaining Voltage-
: $V_{CEO(SUS)} = 825V$ (Min)
- High Switching Speed

APPLICATIONS

- Designed for use in horizontal deflection circuits of color TV receivers.

ABSOLUTE MAXIMUM RATINGS($T_a=25$)

SYMBOL	PARAMETER	VALUE	UNIT
V_{CES}	Collector- Emitter Voltage($V_{BE} = 0$)	1200	V
V_{CEO}	Collector-Emitter Voltage	825	V
V_{EBO}	Emitter-Base Voltage	7.5	V
I_C	Collector Current- Continuous	8	A
I_{CM}	Collector Current-Peak	15	A
I_B	Base Current- Continuous	4	A
I_{BM}	Base Current-Peak	6	A
P_C	Collector Power Dissipation @ $T_C=25$	45	W
T_J	Junction Temperature	150	
T_{stg}	Storage Temperature Range	-65~150	

SYMBOL	PARAMETER	MAX	UNIT
$R_{th\ j-c}$	Thermal Resistance, Junction to Case	2.8	/W

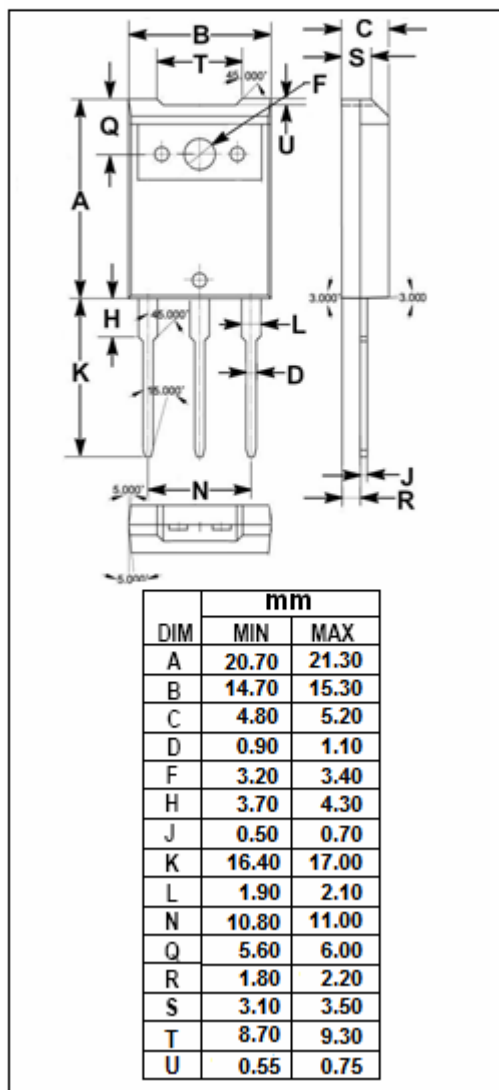
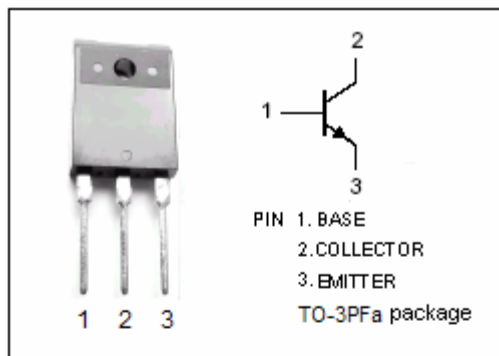

Silicon NPN Power Transistor

BU2708AF

ELECTRICAL CHARACTERISTICS

T_C=25 unless otherwise specified

SYMBOL	PARAMETER	CONDITIONS	MIN	TYP.	MAX	UNIT
V _{CEO(SUS)}	Collector-Emitter Sustaining Voltage	I _C = 100mA ; I _B = 0, L= 25mH	825			V
V _{(BR)EBO}	Emitter-Base Breakdown Voltage	I _E = 1mA; I _C = 0	7.5			V
V _{CE(sat)}	Collector-Emitter Saturation Voltage	I _C = 4A; I _B = 1.33A			1.0	V
V _{BE(sat)}	Base-Emitter Saturation Voltage	I _C = 4A; I _B = 1.33A			1.0	V
I _{CES}	Collector Cutoff Current	V _{CE} = 1200V ; V _{BE} = 0 V _{CE} = 1200V ; V _{BE} = 0; T _C =125			1.0 2.0	mA
I _{EBO}	Emitter Cutoff Current	V _{EB} = 6V ; I _C = 0			70	μA
h _{FE-1}	DC Current Gain	I _C = 0.1A ; V _{CE} = 5V		21		
h _{FE-2}	DC Current Gain	I _C = 4A ; V _{CE} = 1V	3		7.3	